

ST02907CH

FAA Supplemental Type Certificate



Installation of ECS EZMount™ Mechanical Mounting Assemblies on Boeing 747 Series Aircraft (FAA STC ST02907CH)

OVERVIEW

- » FAA STC ST02907CH
- » European Aviation Safety Agency (EASA) STC 10040901

INTRODUCTION

The STCs govern the installation of EZMount™ mechanical mounting assemblies in accordance with Electronic Cable Specialists (ECS) Master Data List ECS-209135.

YOUR NEEDS

Provides modernized EFB system mounting provisions for select Boeing 747 series aircraft.

YOUR BENEFITS

Incorporation of STC ST02907CH is required to support separate installation and operational approval of an EFB system in the cockpit. Once installed, the complete EFB system will provide flight crews the ability to interact with electronic maps, charts, and manuals in lieu of accessing standard paper documentation. System installation will reduce materials costs and aircraft weight without compromising ergonomic concerns.

STC AIRCRAFT EFFECTIVITY

- » Boeing 747-400/-400D/-400F series aircraft

STC LIMITATIONS

- » None

STC CONFIGURATIONS

- » Configuration 1: Installation of two EZMount™ Tilt mechanical mounting assemblies on the captain's and first officer's side of the aircraft cockpit.

Contact CarlisleIT for usage rights, derivative configurations, and installation lead time (800) 327-9473 • sales@carlisleit.com

PRODUCT DESCRIPTION

This project installs ECS EZMount™ Tilt mounting assemblies on the lower section of both #2 windows of a Boeing 747.

ELECTRICAL CHANGES

- » The switch and wiring for a work table on the captain's and first officer's flight bag area will be removed. The existing wires will be capped and stowed per standard procedures.
- » No LRUs will be installed, no power will be connected, and no circuit breakers will be installed to support the EZMount™ Tilt assemblies.

MECHANICAL CHANGES

- » The lower window shroud is removed.
- » The window shroud support assembly and window shade assembly are removed.
- » Mounting brackets for the EZMount™ Tilt are installed on the lower window frame using the existing mounting locations for the window shroud support and window shade assemblies. Inserts are added to the vertical sidewall panel and additional mounting brackets are installed using the new inserts.
- » The window shroud support assembly and window shade assembly are reinstalled.
- » The lower window shroud is trimmed to the EZMount™ Tilt mounting brackets and reattached to the lower frame of the window.
- » Cosmetic sheet metal components are added to cover open areas where the lower window shroud was trimmed.
- » The EZMount™ Tilt is attached to the mounting bracket (see Figure 2).

ST02907CH

FAA Supplemental Type Certificate

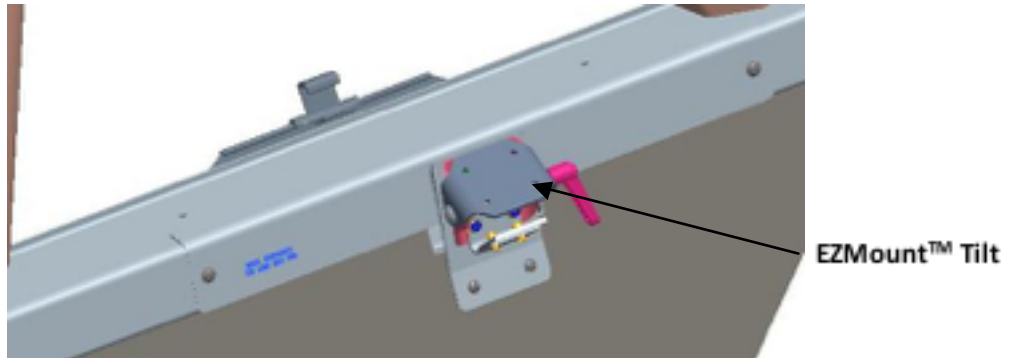

FIGURE 2 - CAPTAIN SIDE WINDOW MODIFIED WITH EZMOUNT™ TILT
(FIRST OFFICER INSTALLATION IS MIRROR IMAGE)

CONNECT WITH US TODAY

See CarlisleIT's line of **Certification Services** at:
CarlisleIT.com/services/certification-stc-engineering

(+1) 904-494-0549
Sales@CarlisleIT.com