

CONFIGURATION	ASSEMBLY PN, ref	SHEET (S)
2 POSITION	TMB-SEH22-XX	SEE SHEET 1,2
4 POSITION	TMB-SEH24-XX	SEE SHEET 1,2
6 POSITION	TMB-SEH26-XX	SEE SHEET 1,2
8 POSITION	TMB-SEH28-XX	SEE SHEET 1,3
10 POSITION	TMB-SEH210-XX	SEE SHEET 1,3

REVISIONS			
REV.	DESCRIPTION	DATE	BY
P1	PRELIMINARY RELEASE	03.29.20	HT
01	ADD AREA TO BE ETCH TO PREVENT SOLDER FLOW INTO CONNECTOR THREADED HOLE; ADD NOTE "SOLDEMASK FREE AREA"	08.15.20	HT
02	REMOVE "AREA TO BE ETCHED & FREE OF SOLDER MASK"	08.16.20	HT

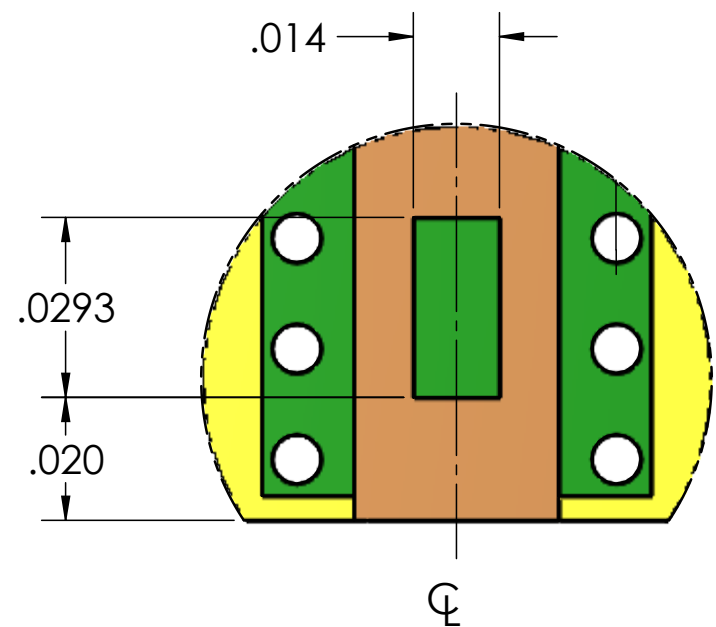

DETAIL D
LAYER 2 - Cu
SCALE 32 : 1

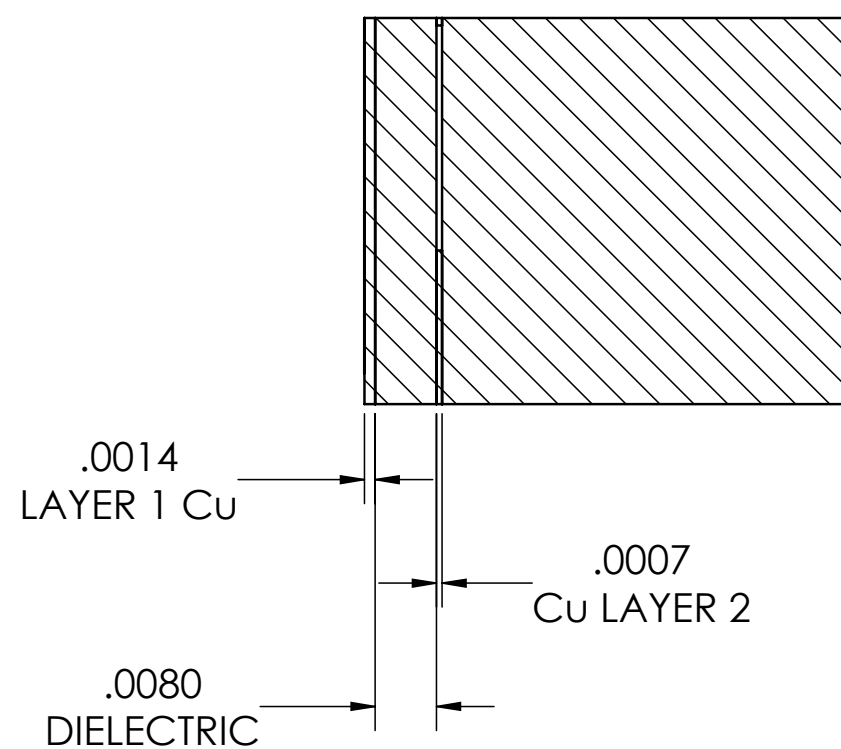

SECTION B-B
SCALE 40 : 1

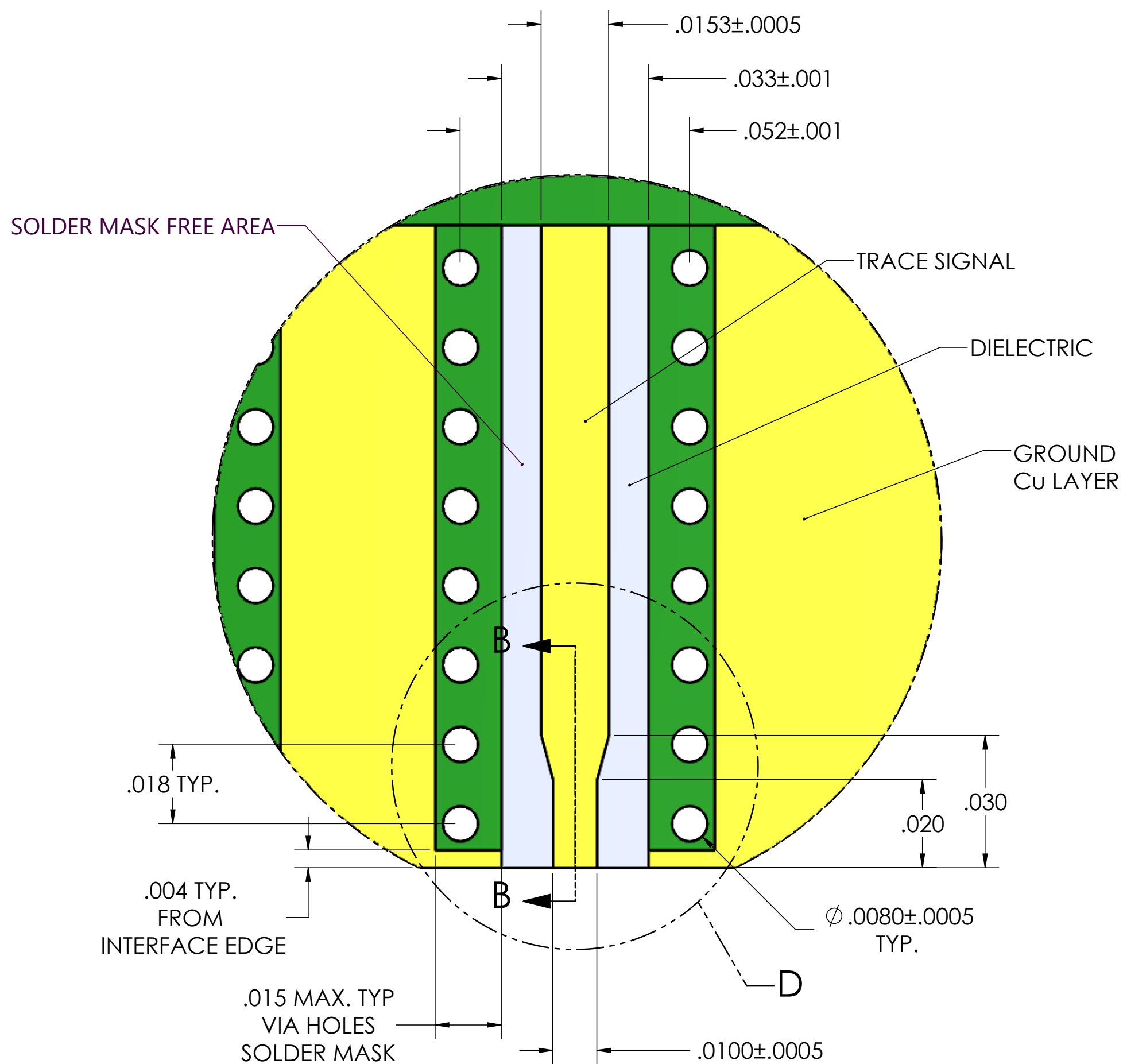

LAYER1 - Cu
SCALE 40 : 1

APPLICABLE CARLISLE IT DOCUMENTS

WORK STANDARD	PROD INSTRUC	ASSY INSTRUC
NA	NA	NA
-	-	-

NOTICE
THIS DRAWING EMBODIES A CONFIDENTIAL PROPRIETARY DESIGN ORIGINATED BY CARLISLE INTERCONNECT TECHNOLOGIES & ALL DESIGN, MANUFACTURING, REPRODUCTION, USE & SALE RIGHTS REGARDING THE SAME ARE EXPRESSLY RESERVED. IT IS SUBMITTED UNDER A CONFIDENTIAL RELATIONSHIP FOR A SPECIFIED PURPOSE & THE RECIPIENT AGREES BY ACCEPTING THIS DRAWING NOT SUPPLY OR DISCLOSE ANY INFORMATION REGARDING IT TO ANY UNAUTHORIZED PERSON TO INCORPORATE IN OTHER PROJECTS ANY SPECIAL FEATURES PECULIAR TO THIS DESIGN. ALL PATENT RIGHTS HERETO ARE EXPRESSLY RESERVED BY CARLISLE INTERCONNECT TECHNOLOGIES, CERRITOS, CALIFORNIA 90703.

TOLERANCES AND NOTES
EXCEPT AS NOTED

- DIMENSIONS ARE IN INCHES.
XX ± .015
LINEAR XXX ± .005 ANGULAR ± 1/2°
FRACTION ± 1/32
- MACHINE FINISH: 63/RMS
 - BREAK ALL SHARP EDGES .003 MAX.
 - MACHINED FILLETS .005 MAX.
 - MACHINED SURFACES SQUARE TO RESPECTIVE AXIS WITHIN .005 INCHES PER INCH.
 - MACHINED DIAMETERS CONCENTRIC WITHIN .002 T.I.R.
 - DIMENSIONS TO BE MET BEFORE PLATING.
 - CHAMFER ALL THREADS 45°.
 - THREADS PER H-28
 - REMOVE FRAVED EDGES ON TEFLON.
 - REMOVE ALL BURRS.

APPROVAL	INITIALS	DATE
DRAWN BY	HT	03.29.20
CHECKED BY	-	-
TEST ENGR	-	-
QUALITY	-	-
DESIGN ENGR	HT	03.29.20
MFG. ENGR		
ECO APPRV		

MATERIAL		SPECIFICATION	PROCUREMENT
-		-	
CARLISLE Interconnect Technologies Cerritos, CA 90703		TITLE HC2(2.5mm)-EDGE LAUNCH, FOOTPRINT	
SCALE 4:1	SUB-DIRECTORY/	SHEET 1 OF 3	
SIZE C	CAGE CODE 30990	DRAWING NO. TMB-SEH2X-FOOTPRINT	REV. 02

4

3

2

1

D

D

C

C

B

B

A

A

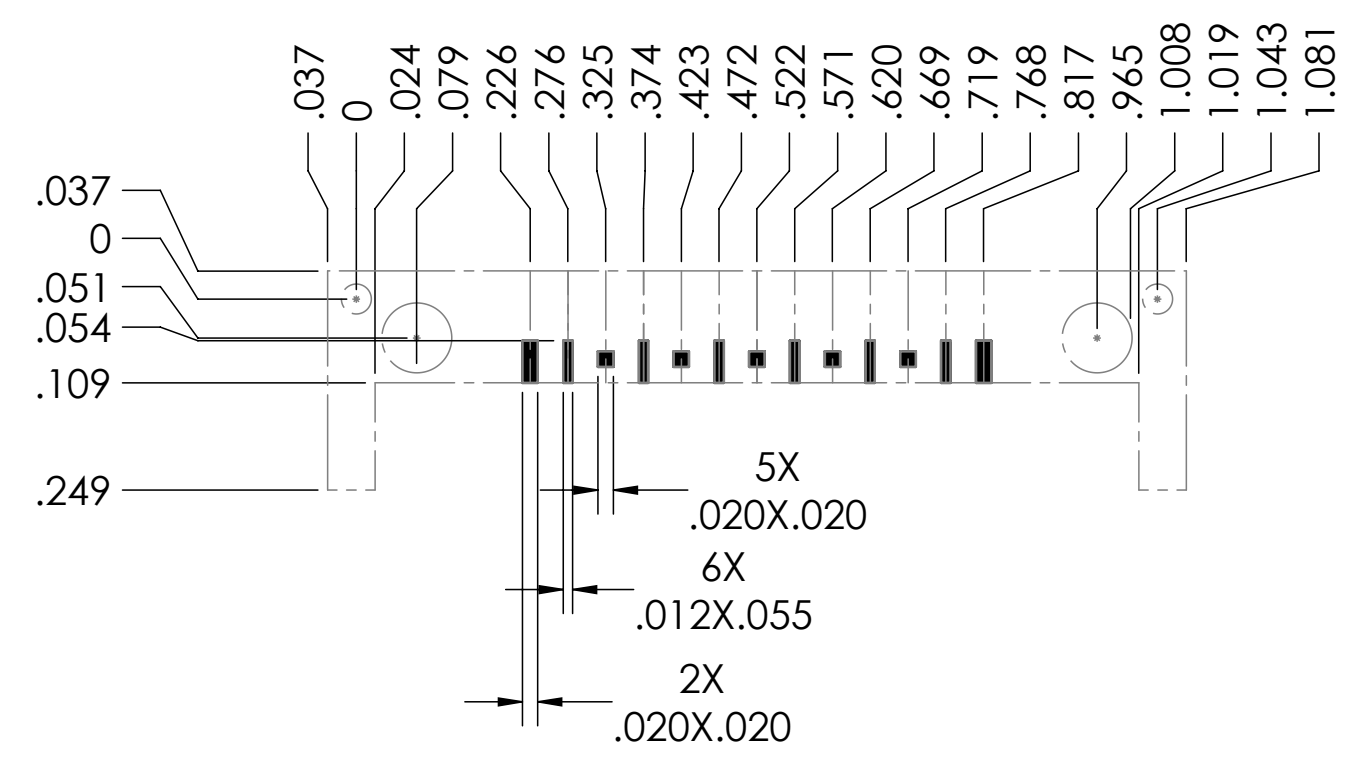
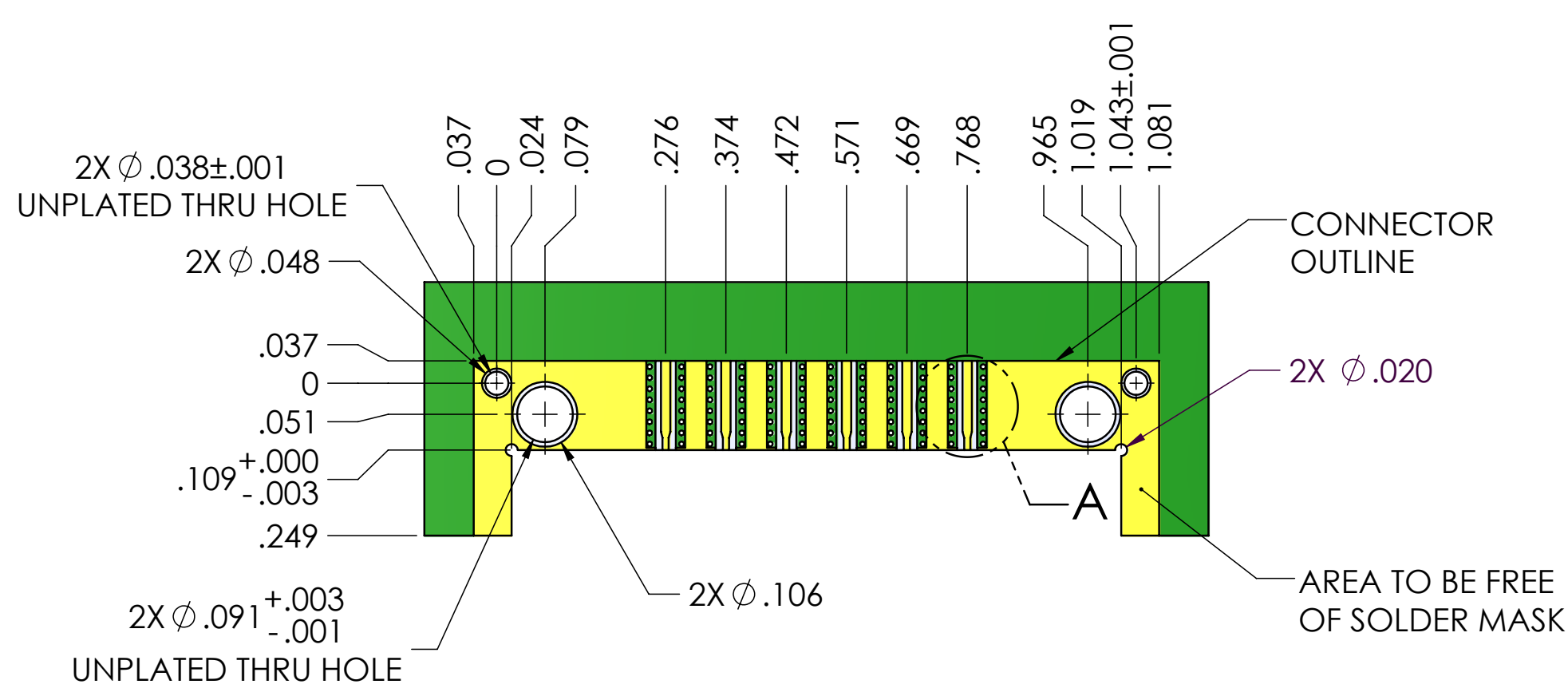
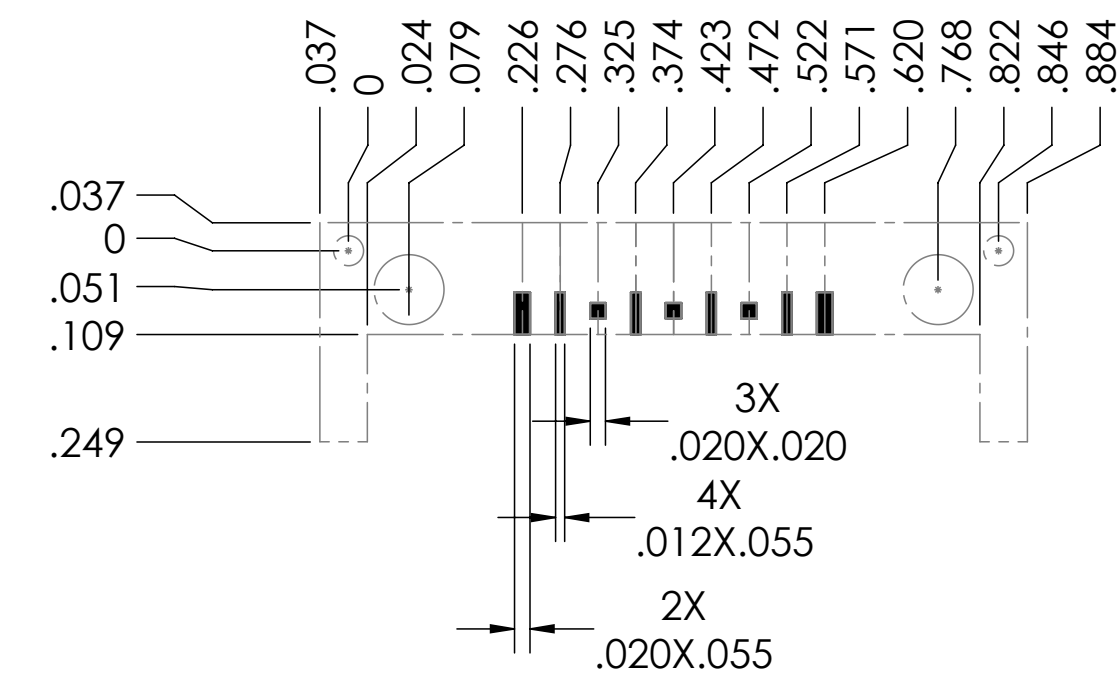
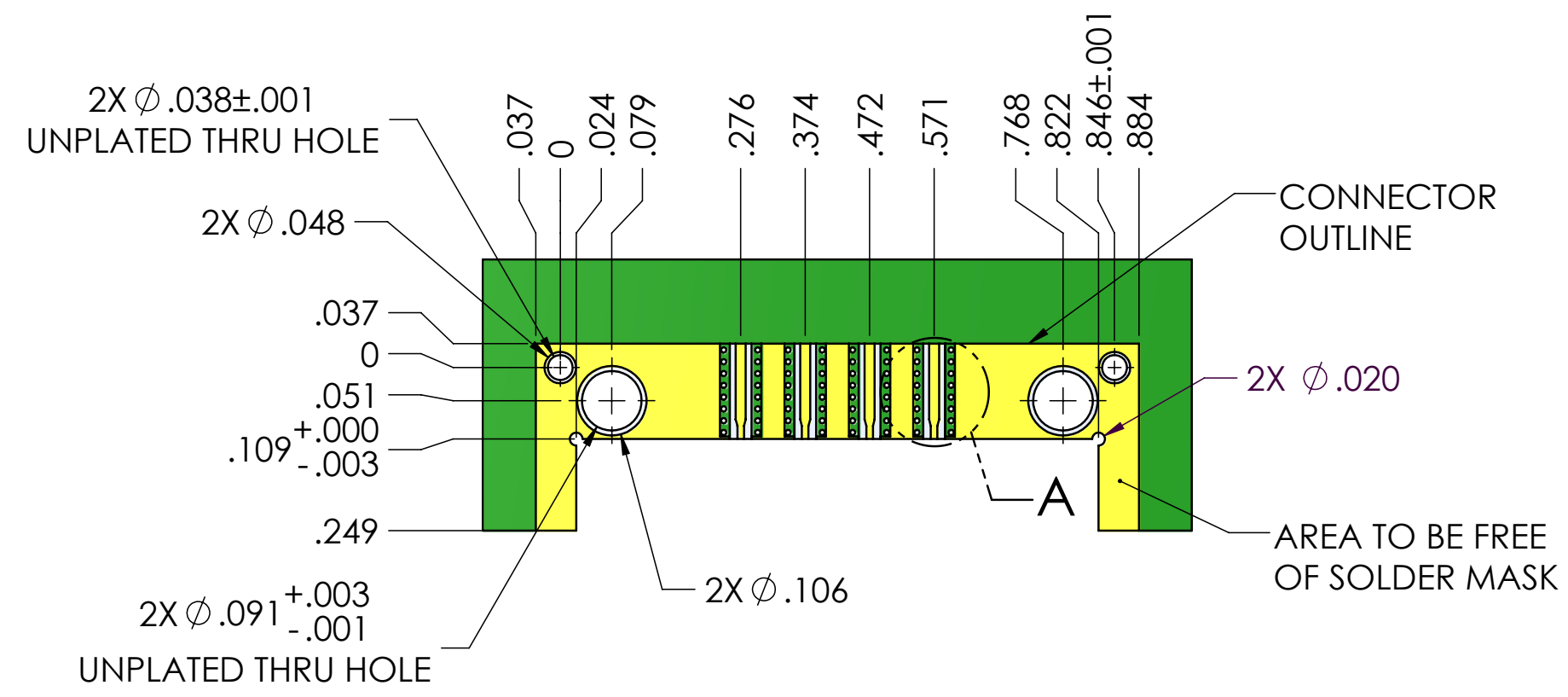
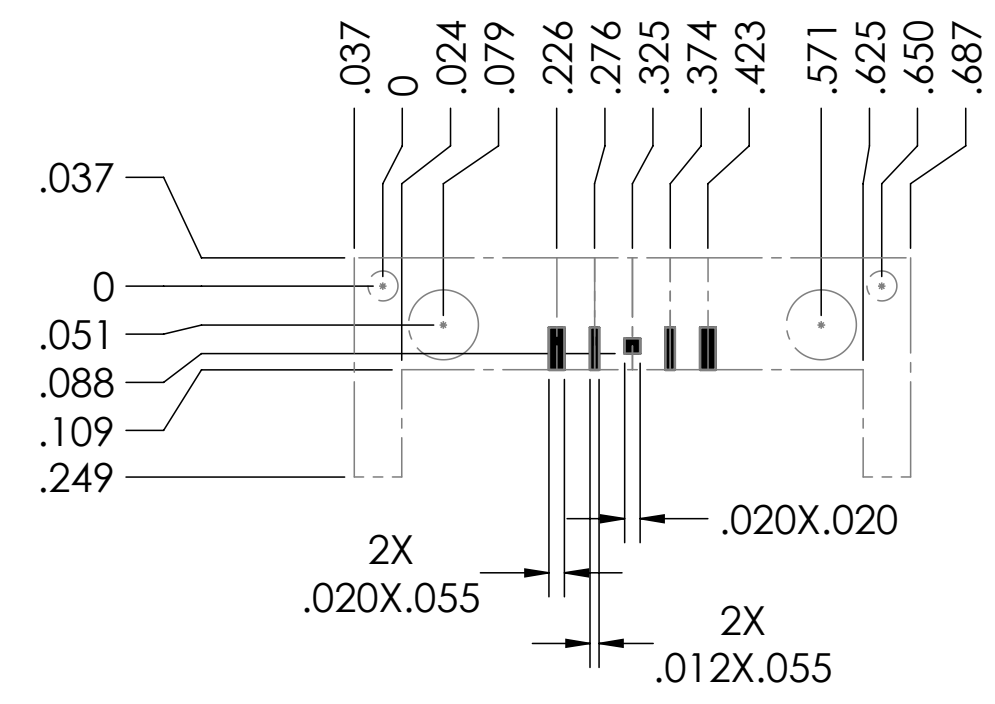
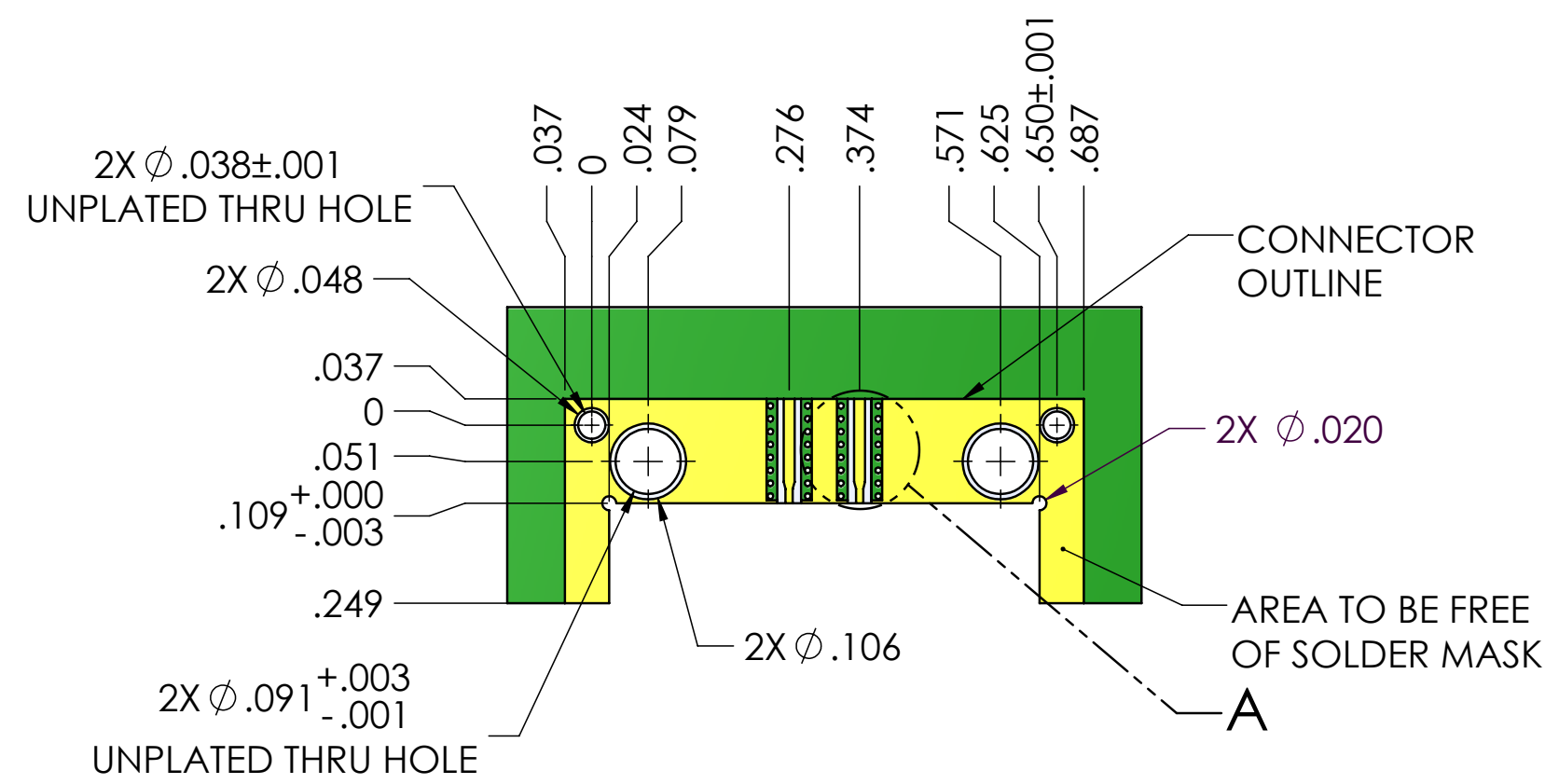

HC2(2.5mm) EDGE LAUNCH-RECOMMENDED FOOTPRINT

FOOTPRINT STENCIL

4

3

2

1

SCALE	SUB-DIRECTORY/		SHEET 2 OF 3
4:1			
SIZE	CAGE CODE	DRAWING NO.	REV.
C	30990	TMB-SEH2X-FOOTPRINT	02

4 3 2 1

D

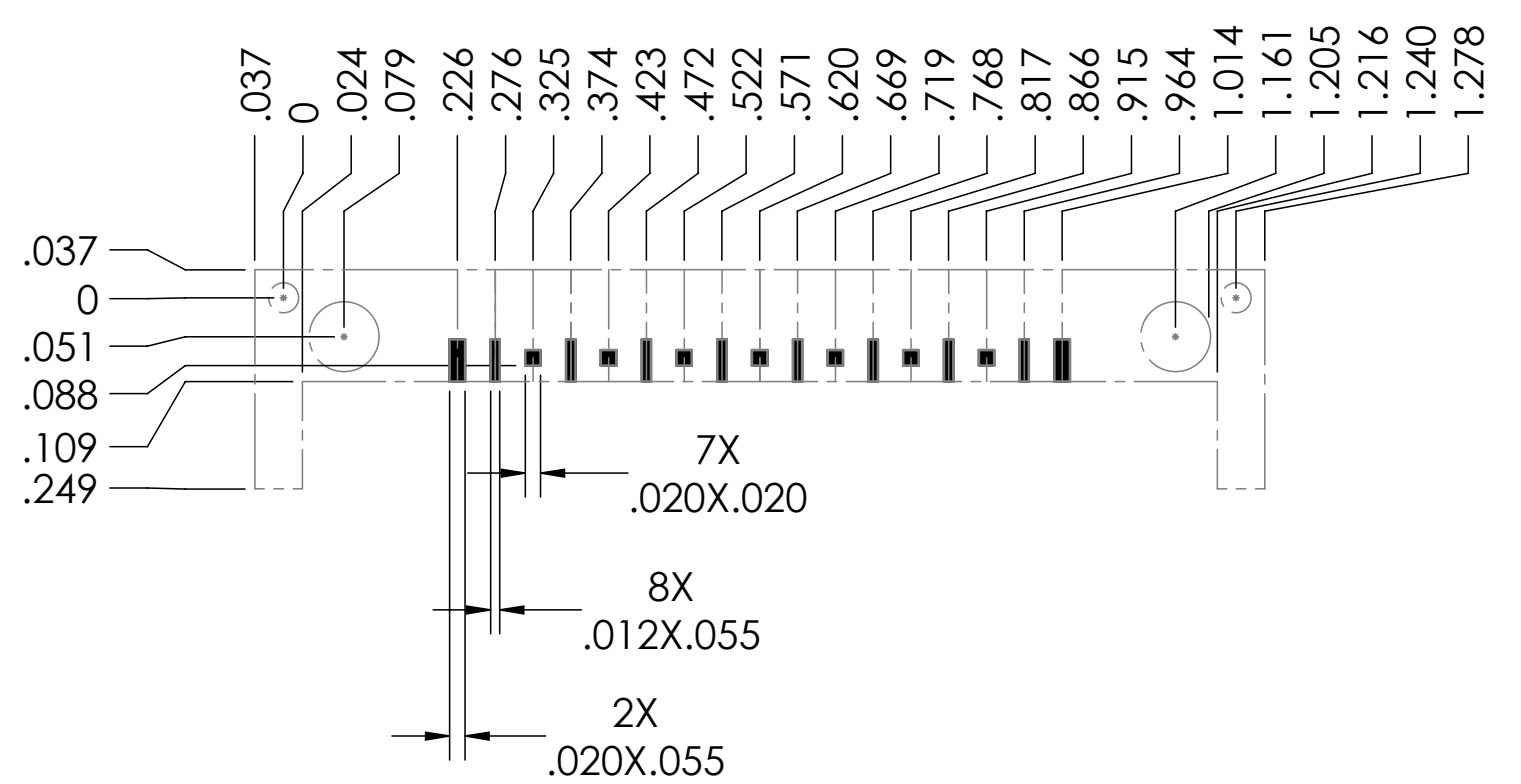
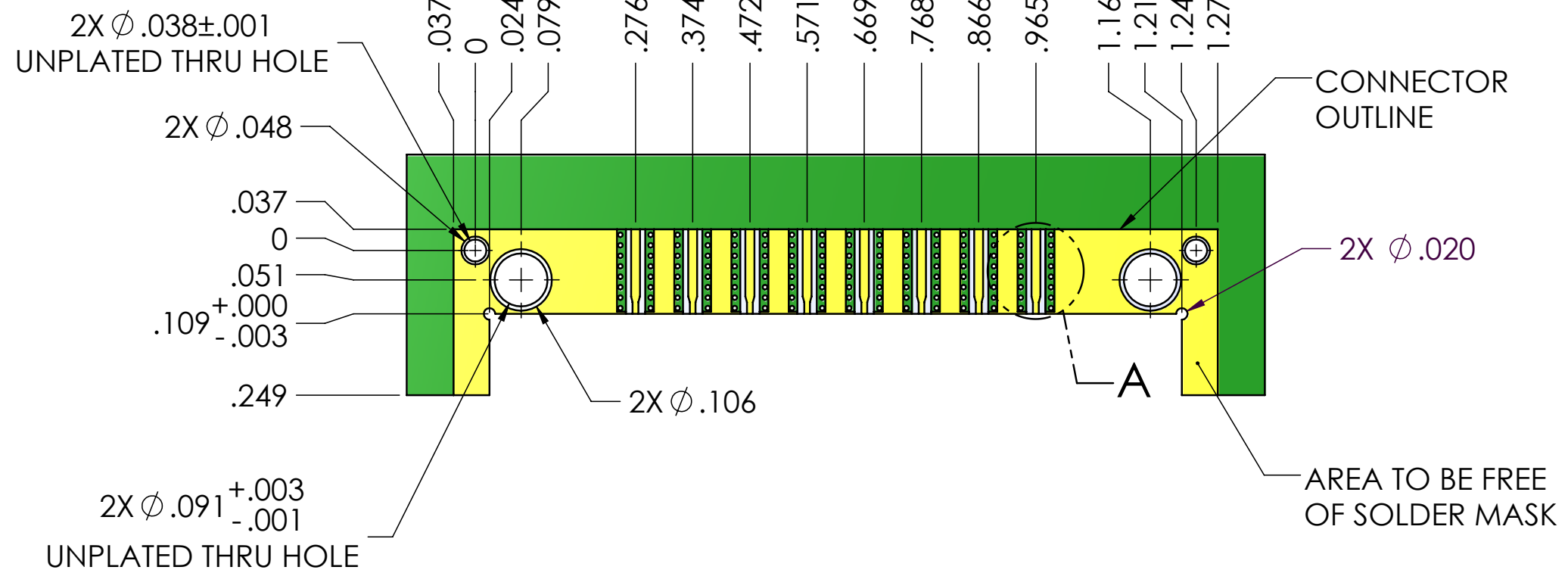

C

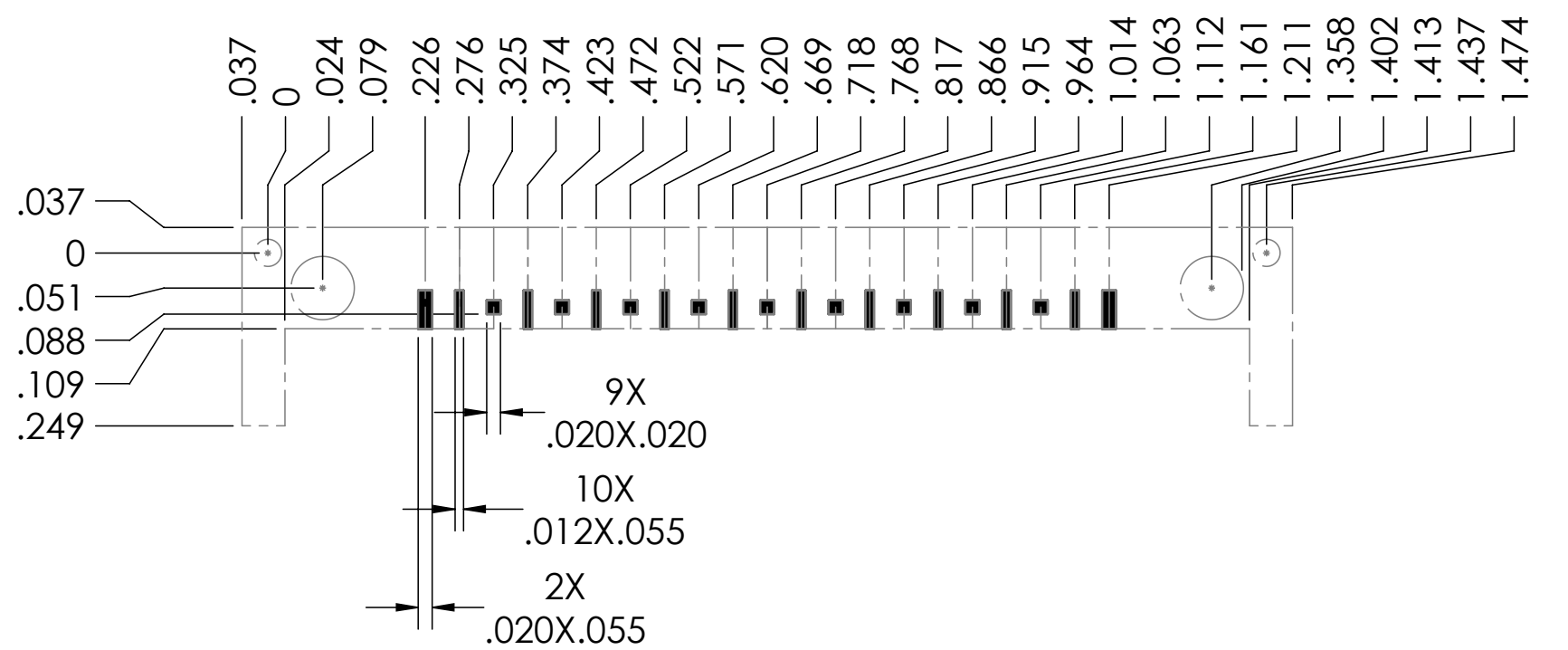
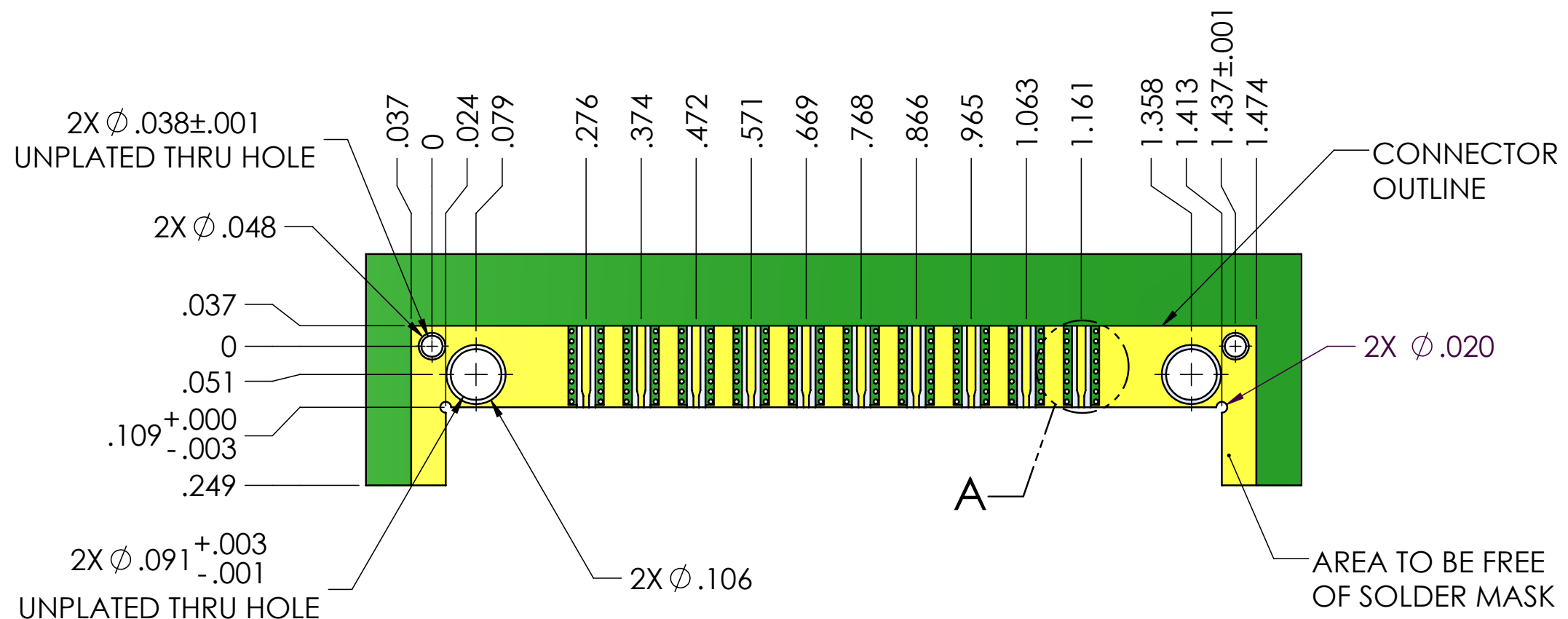

A

HC2(2.5mm) EDGE LAUNCH-RECOMMENDED FOOTPRINT

FOOTPRINT STENCIL

4 3 2 1

SCALE	SUB-DIRECTORY/		SHEET 3 OF 3
4:1			
SIZE	CAGE CODE	DRAWING NO.	REV.
C	30990	TMB-SEH2X-FOOTPRINT	02