

REV.	REGION	DESCRIPTION	DATE	DWN
00		Preliminary released	19.Feb.20	Bob

SPECIFICATIONS:

ELECTRICAL RATINGS

Impedance	50 ohm
Frequency Range	0 ~ 34 GHz
V.S.W.R.	1.30 max. at 34 GHz
Insertion Loss	≤ 0.35 DB at 34 GHz
Working Voltage (at Sea Level)	400 V RMS max.
Dielectric Withstanding Voltage (at Sea Level)	500 V RMS min.
Contact Resistance	
Center Contact	1.5 Milliohms max.
Outer Contact	0.8 Milliohms max.
Insulation Resistance	5000 megohms min.
Temperature Range	-55°C to +85°C
Durability	≥ 500 Cycles

NOTES:

- These characteristics are typical and for reference.
- ▲ Represents a critical dimension.
- ▲ 3. Pushout force for insulator: 44.48 N (10 LB) min.
- ▲ 4. Pushout force for pin: 13.35 N (3 LB) min.
- ⚠ Product to be packaged 100 parts per tray.
(1 part per pocket)
- ⚠ Protection cap must be installed before packing.

RoHS Compliant

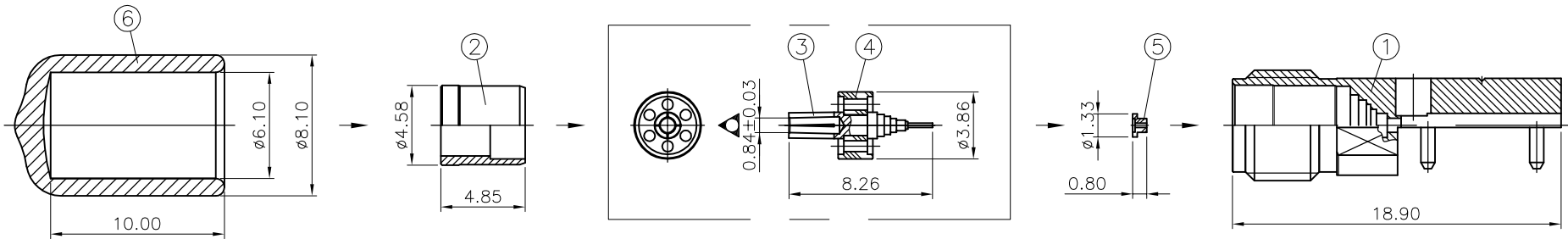
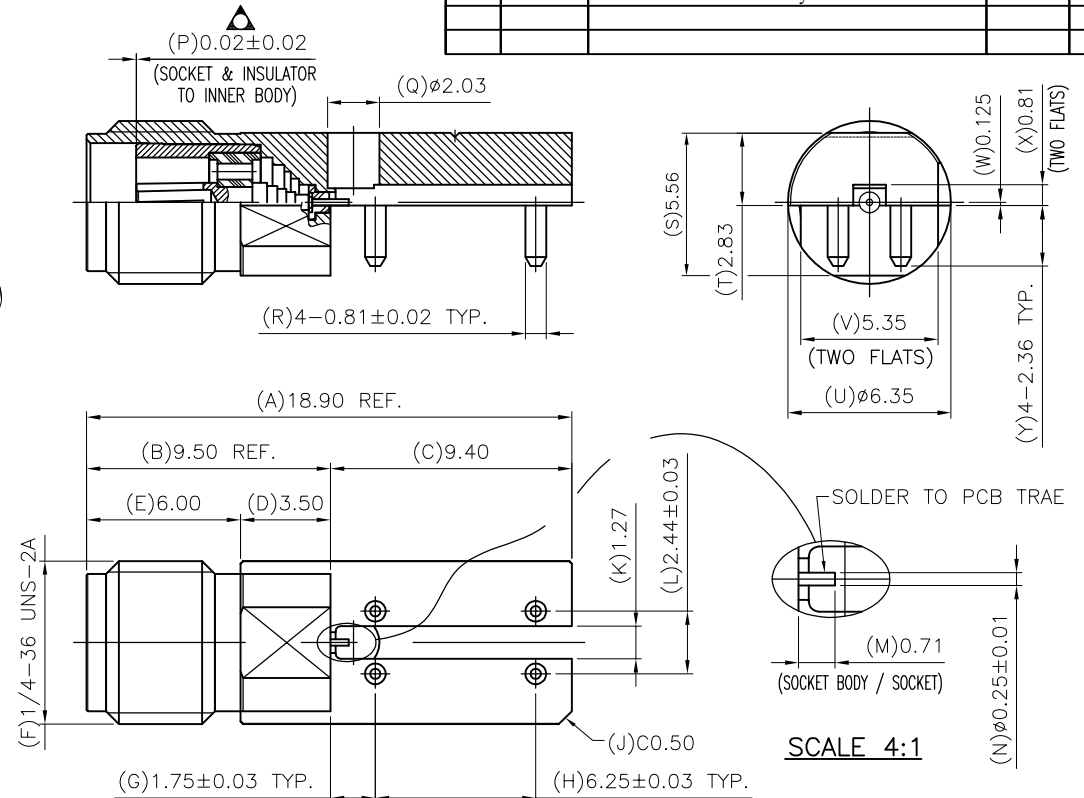
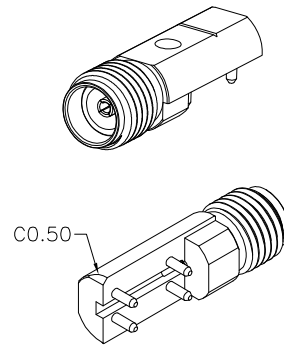

ITEM	DESCRIPTION	MATERIAL	FINISH	Q'TY
6	PROTECTION CAP	SOFT PVC (PURPLE)	N/A	1
5	INSULATOR 2	PTFE (WHITE)	N/A	1
4	INSULATOR 1	PTFE (WHITE)	N/A	1
3	SOCKET	BeCu C17300	Cu0.75um Ni2.50um Au0.75um	1
2	INNER BODY	BRASS C3604B	Cu0.75um Ni2.50um Au0.25um	1
1	BODY	BRASS C3604B	Cu0.75um Ni2.50um Au0.25um	1

▲ KEY DIMENSION NEED 100% INSPECTION	Drawn: Bob	CARLISLE INTERCONNECT TECHNOLOGIES	Dongguan City, Guangdong P.R. China 523533	
	Checked: Emad			
(XX) REF. DIMENSION FOR REF. ONLY	Approved: Emad	Material: SEE BOM	Project Name:	
Information contained on this drawing is confidential and may also contain proprietary CARLISLE/customer information. Drawing content is only intended for use of the above customer. If you are not the intended recipient or authorized employee of above company name, you are hereby notified any use, duplication, reconstruction, or distribution of drawing information is strictly prohibited.		Part Numble: TMB-E5FS-1ST	3.5mm STR. JACK EDGE MOUNT (WITH FEET), PCB CONNECTOR, WITH .010" PIN	
		SIZE A4	Part Name: Connector Assembly	Revision: 00
			Date: 19.Feb.20	SHEET 1 OF 2

DO NOT SCALE DRAWING

REV.	REGION	DESCRIPTION	DATE	DWN
00		Preliminary released	19.Feb.20	Bob

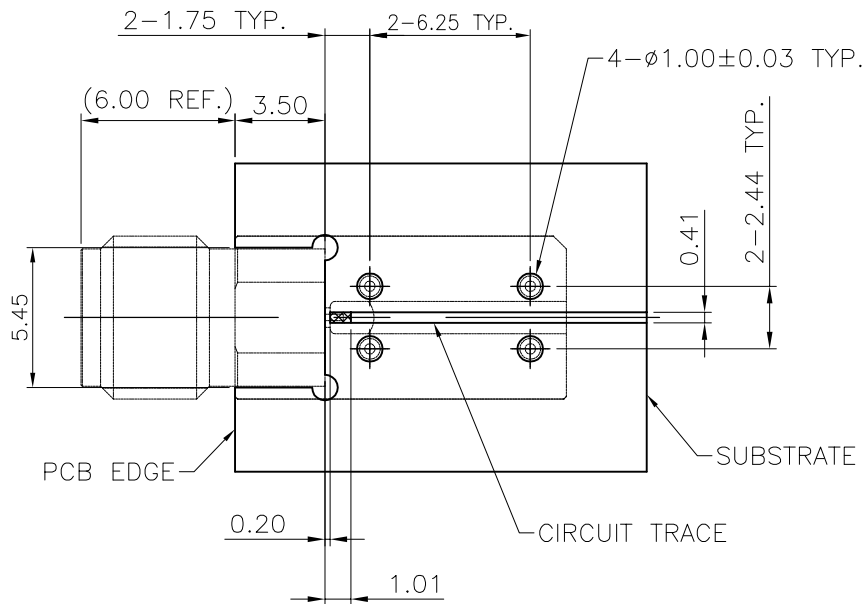

(OPTION 1)

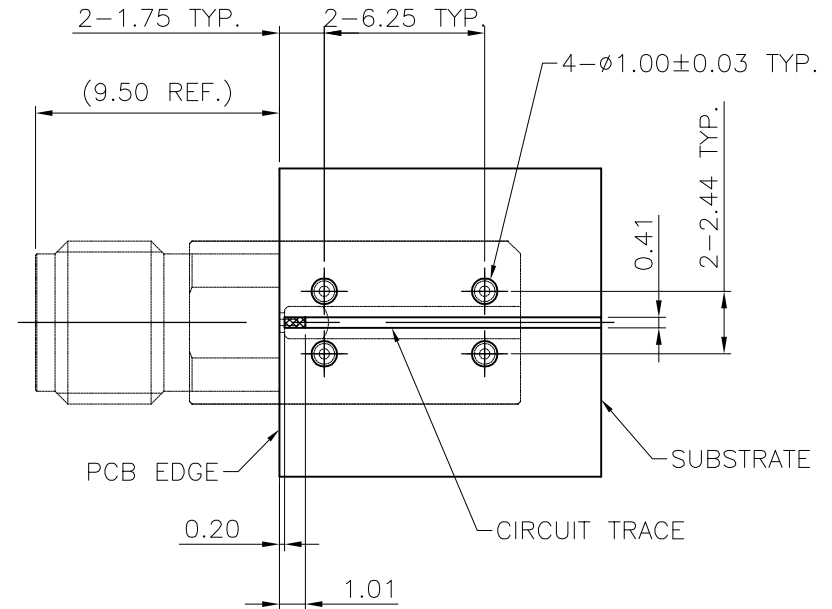

(OPTION 2)

RECOMMENDED PCB LAYOUT

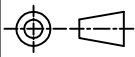
▲ KEY DIMENSION NEED 100% INSPECTION (XX) REF. DIMENSION FOR REF. ONLY	Drawn: Bob	 Dongguan City, Guangdong P.R. China 523533	
	Checked: Emad		
Information contained on this drawing is confidential and may also contain proprietary CARLISLE/customer information. Drawing content is only intended for use of the above customer. If you are not the intended recipient or authorized employee of above company name, you are hereby notified any use, duplication, reconstruction, or distribution of drawing information is strictly prohibited.	Approved: Emad	Material: SEE BOM Part Numble: TMB-E5FS-1ST	Project Name: 3.5mm STR. JACK EDGE MOUNT (WITH FEET), PCB CONNECTOR, WITH .010" PIN
	SIZE A4	 Part Name: Connector Assembly	Revision: 00 Date: 19.Feb.20
	DO NOT SCALE DRAWING		SHEET 2 OF 2