

This print and associated documents and the contained information are the confidential property of ELECTRONIC CABLE SPECIALISTS. Disclosure of, and/or reproduction of, all or part thereof or manufacture of any part from information contained on this print not specifically permitted by ELECTRONIC CABLE SPECIALISTS in writing is forbidden.

DWG NO.		6080		SH	1	REV.	D	1	
REVISIONS									
ECN	SHT	ZONE	REV.	DESCRIPTION			DATE	APPROVED	
			N/C	RELEASED					
			A	SEE ECN 128, 142, & 566			DS 11/15/93	C ASSEF W SIEBERT	
			B	SEE ECN 659			DS 12/7/93	C ASSEF W SIEBERT	
			C	SEE ECN 874			JS 1/24/94	C ASSEF W SIEBERT	
9824	1	A8	D	ADDED NOTE 7			JTS 3/3/00	L. Heibel	

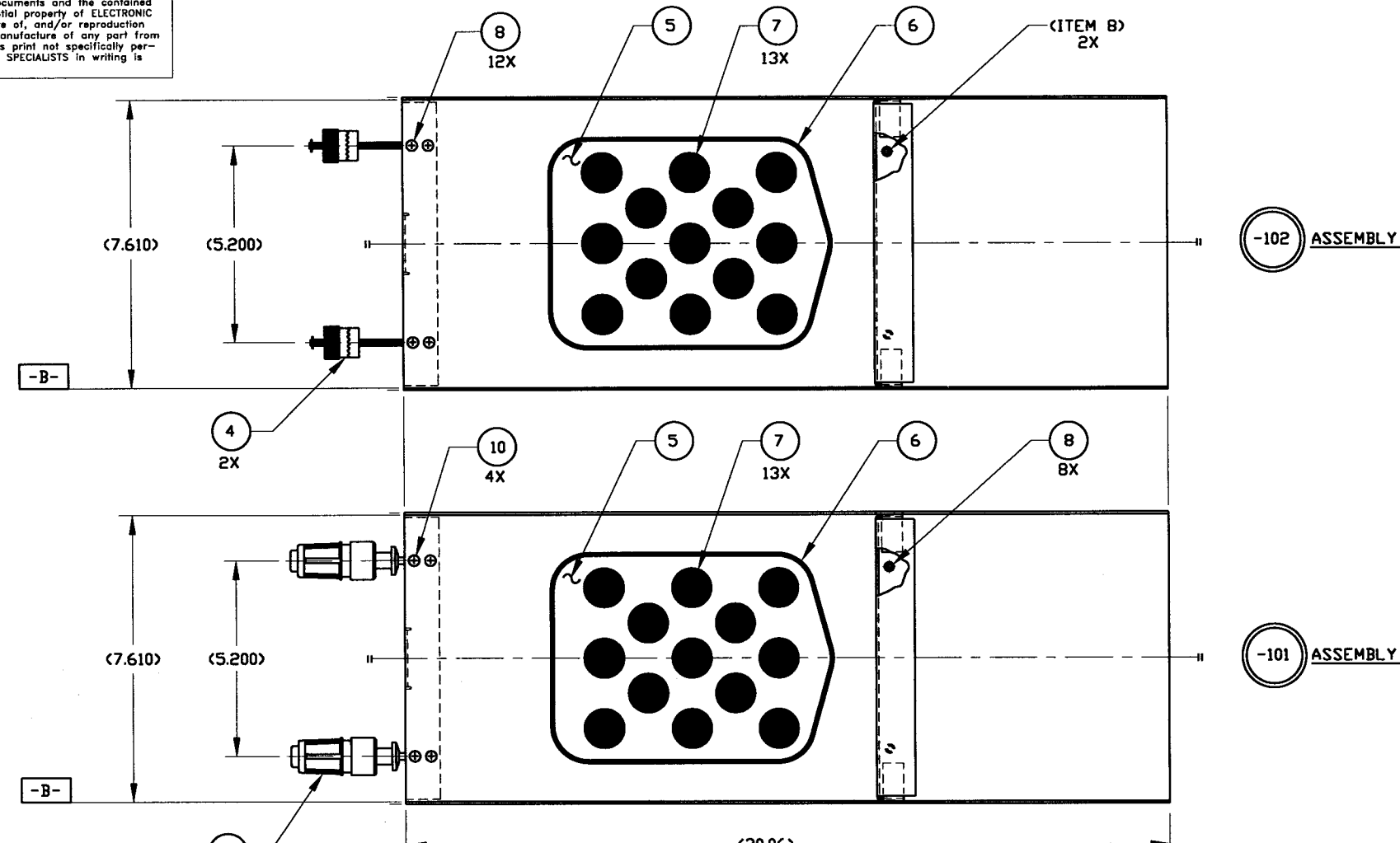

(SIZE 3 CONNECTOR CUT-OUT PER ARINC 600)

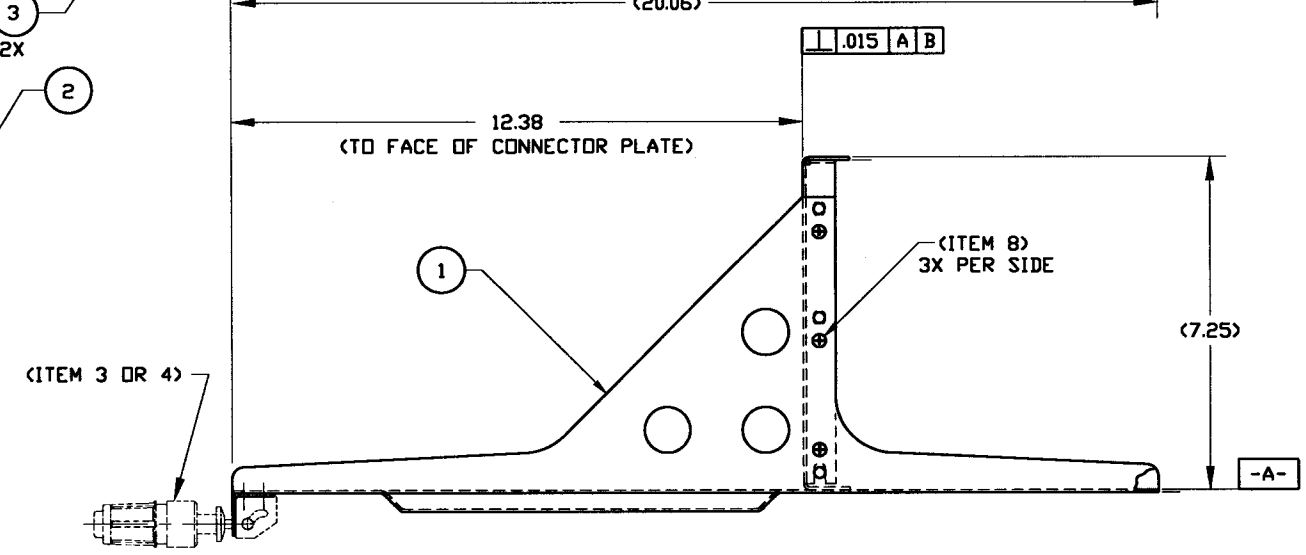
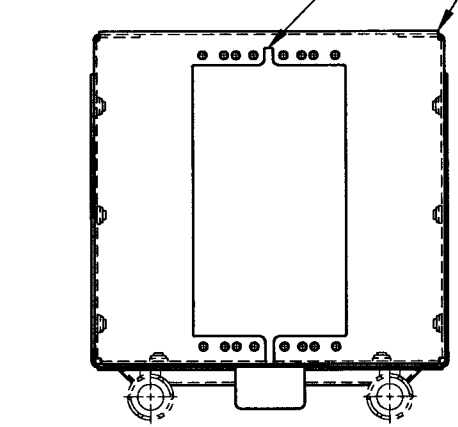

QTY REQ'D	QTY REQ'D	QTY REQ'D	QTY REQ'D	COMPONENTS PART NO. OR IDENTIFYING NO.	NOMENCLATURE OR DESCRIPTION	MATERIAL/SPECIFICATION	CAGE CODE	ITEM NO.
4	—	—	4	MS24693-C25	SCREW, FLAT HEAD	(.138-32 X .25 LONG)		10
1	—	—	—	10454-202	TRAY WELDING ASSY, 6 MCU	(.063 AL ALLOY 6061)		9
8	8	12	8	MS24693-C26	SCREW, FLAT HEAD	(.138-32 X .38 LONG)		8
13	13	13	13	LAVELLE P/N 40-8PB	PLUG BUMPER	(RUBBER)	98893	7
1	1	1	1	10016-106	DEFORMATION SEAL ASSY, 6 MCU	(SILICONE RUBBER)		6
1	1	1	1	10024CC-01	METERING PLATE, 6 MCU	(.040 AL ALLOY 5052 OR 6061)		5
—	—	—	2	S0076-105	HOLD DOWN ASSY, THUMBSCREW			4
2	—	—	2	10344-101	HOLD DOWN ASSY, INSERTION/EXTRACTION		OCBV7	3
1	1	1	1	10018CC-108	CONNECTOR PLATE ASSY, 6 MCU	(.063 AL ALLOY 6061)		2
—	1	1	1	S0079CC-126	TRAY WELDING ASSY, 6 MCU	(.063 AL ALLOY 6061)		1

- 7. IDENTIFY WITH ECS P/N AND LOT#, PER EP210.
 - 6. MEETS OR EXCEEDS THE REQUIREMENTS OF RTCA/D0-160C AND FAR 25-561.
 - 5. MEETS OR EXCEEDS ARINC 600 SPECIFICATIONS.
 - 4. ALTERNATE PART NO.: ECS S0076-101.
 - 3. ALTERNATE PART NO.: RAM CA12145-102.
 - 2. FINISH: (CLEAR CHEM FILM PER MIL-C-5541, CLASS 3).
 - 1. DIMENSIONS AND TOLERANCES PER ANSI Y14.5M-1982.
- NOTES: UNLESS OTHERWISE SPECIFIED

THIRD ANGLE PROJECTION

CAD GENERATED DOCUMENT
ANY CHANGES TO THIS DOCUMENT MUST BE SUBMITTED TO THE DESIGN/DRAFTING DEPARTMENT FOR PROPER UPDATE

WGT	STRESS	PRODUCTION	QUALITY ASSURANCE	ADDITIONAL APPROVALS
-104	FINAL	93-0888		
-103	FINAL			
-102	FINAL			
-101	FINAL			

UNLESS OTHERWISE SPECIFIED DIMENSIONS ARE IN INCHES TOLERANCES ARE:

FRACTIONS	DECIMALS	ANGULAR
±	± .03	± 1°

TREATMENT: DO NOT SCALE DRAWING

FINISH: _____

SIMILAR TO: _____ ACT. WT: _____

CONTRACT NO. _____

DRAWN BY: D SWITALSKI DATE: 10/28/92

CHECKED BY: C ASSEF DATE: 10/28/92

DESIGNED BY: C ASSEF DATE: 10/28/92

PROJECT ENGR: B KOJIS DATE: 10/28/92

MFG ENGR: _____ DATE: _____

ENGR MGR: W SIEBERT DATE: 10/28/92

ELECTRONIC CABLE SPECIALISTS
FRANKLIN, WI 53132
PHONE: (414) 421-5500

TRAY ASSY, 6 MCU SHORT/LONG

SIZE: D CAGE CODE: 66197 C/A DWG NO.: 6080

SCALE: 1/2 EFFECTIVITY: _____ SHEET: 1 OF 3